

Modeling and Robust Deflection Control of Piezoelectric microActuators modelled by Zero-Order Numerator Interval System

S. Khadraoui, M. Rakotondrabe and P. Lutz

*FEMTO-ST Institute, UMR CNRS 6174 - UFC / ENSMM / UTBM
Automatic Control and Micro-Mechatronic Systems depart., AS2M
24, rue Alain Savary, 25000 Besançon - FRANCE
{sofiane.khadraoui,mrakoton,plutz}@femto-st.fr*

Abstract: Piezoelectric actuators have received an increasing attention these last years thanks to the high resolution of displacement, high force density and fast response time that can offer piezoelectric materials. However, piezoelectric actuators are highly sensitive to environmental disturbances and typify strong nonlinearities that undeniably reduce the expected positioning accuracy. H_∞ or μ -synthesis techniques were often used to control these actuators. However, these techniques derive high-order controllers which are hard to implement and that therefore impede the development of real packaged microsystems.

This paper aims to design low-order controller ensuring robust performances for piezoelectric actuators. In the approach, first we use a linear model with uncertain parameters that are bounded by interval numbers. Then, on the basis of the interval model and the required performances, a low order controller is computed using a direct synthesis method. The proposed method is suitable for a class of models: transfer functions with zero-order numerator. The experiments confirm the robustness of the proposed method.

Keywords: Piezoelectric actuators, Microgrippers, Robust control, Interval systems, Parametric uncertainties.

1. INTRODUCTION

Smart materials play an important role in the development of microsystems and microrobots, and generally for applications at the micro and nano-scale. Piezoelectric materials are widely used because of their high resolution (in the range of nanometers) and their high bandwidth (Devasia et al. (2007)). Furthermore, they can be used as measuring elements as well as actuators. In the latter case, they have a large area of practical applications such as the actuation of piezoelectric microgrippers (Haddab et al. (2000)), AFM-tubes for scanning and nanopositioning (Bining et al. (2000)), stepper microrobots (Rakotondrabe et al. (2009)), etc. A piezoelectric microgripper is made up of two piezoelectric cantilevers. It is dedicated to pick, transport and place small objects with high accuracy of positioning and high repeatability in order to perform micromanipulation and microassembly tasks. The dynamical behavior of these piezoelectric actuators often changes during the tasks because of the strong dependency on the environment (temperature, vibrations, etc.), of the interaction and contact with surrounding systems (objects, other microsystems) and other characteristics such as nonlinearities. As a result, the accuracy may be lost during the manipulation or assembly. These characteristics should be incorporated during the modeling and control design in order to achieve the required performances. For that, linear

modeling with uncertainties followed by robust closed-loop control techniques are advised to ensure the performances (Devasia et al. (2007) and Rakotondrabe et al. (2009a)).

The control of piezoactuators subjected to uncertainties has been proposed in many works using "classical" robust control laws H_2 , H_∞ and μ -synthesis (Takaba (1998), Su et al. (1998) and Rakotondrabe et al. (2009a)). While these techniques have proved their efficiency, unfortunately they may derive high-order controllers which are not suitable for embedded microsystems. Furthermore, when the number of the considered uncertain parameters increase, their modeling becomes complex. An alternative method is to bound the uncertain parameters by interval numbers and then to derive a robust controller by combining interval arithmetic with classical control design. In addition to the ease and simplicity to represent the parametric uncertainties, such approach allows to derive low-order controllers.

The first idea on interval arithmetic has appeared in 1924 by Burkill and 1931 by Young, then later in 1966 with R.E. Moore's works Moore (1966). Since then, several applications appeared on the subject. Some of them relates to guaranteed estimation, robust stability and controllers design. An approach dealing with guaranteed parameters estimation based on the SIVIA algorithm (Set Inversion Via Interval Analysis) has been addressed in Jaulin and Walter (1993). In Jaulin et al. (2001), Jaulin and Walter (1994) and Kharitonov (1978), the stability analysis of

* This work is supported by the **Conseil Général du Doubs**, France.

the closed-loop with a given controller was proposed using the Routh's criteria and the Kharithonov's theorem. The authors in [Smaginaa and Brewerb \(2002\)](#) proposed an approach in the state space to synthesize stabilizing controller for an interval model. In [Bondia et al. \(2004\)](#), an approach to design robust controller ensuring performances have been proposed. It is based on the inclusion of the set of all possible interval closed-loop inside the set of the feasible reference models that define the wanted performances. The controller computation in [Bondia et al. \(2004\)](#) is formulated as a set-inversion problem, where a check of the inclusions satisfaction is needed for a range of frequencies. [Li and Zhang \(2009\)](#) proposed a control algorithm prediction-based interval model and its application to a welding process. In [Chen and Wang \(2000\)](#), robust controller design method guaranteeing both the robust stability and performances for an interval system is addressed. In the latter work, first a robust stabilizing feedback controller is computed, then a pre-filter is introduced to ensure the performances. In our previous work [Khadraoui et al. \(2010\)](#) it has been shown that interval techniques combined with a linear control theory can be efficiently used to model and to control microsystems.

In this paper, the modeling and robust control of piezoactuators, especially piezocantilevers, dedicated to microgrippers for micromanipulation and microassembly contexts are addressed. Combining interval techniques and a classical control theory, we derive a robust controller ensuring performances. For that, interval models are used to model the piezoactuators. Then a simple controller design called direct synthesis is used to derive the controller. The proposed method is suitable for a class of interval systems: transfer functions with zero-order numerator. Such model structure may be sufficient to represent cantilevered structures piezoactuators ([Rakotondrabe et al. \(2010\)](#)). The designed controller is a low-order controller which makes possible its implementation in real packaged microsystems.

The paper is organized as follows. In section-II, preliminaries related to interval analysis and systems are provided. The computation of the controller by combining interval analysis with the direct synthesis method is presented in section-III. In section-IV we apply the proposed method to control piezoactuators. Finally, experimental results end the paper.

2. MATHEMATICAL PRELIMINARIES

More details on the interval arithmetic can be found in [Moore \(1966\)](#) and [Jaulin et al. \(2001\)](#).

2.1 Definitions

A closed interval number denoted by $[x]$ corresponds to a range of real values and can be represented by a pair of numbers (the left and right endpoint of the interval) as follows:

$$[x] = [x^-, x^+] = \{x \in R / x^- \leq x \leq x^+\} \quad (1)$$

An ordinary real number x can be represented by a degenerate interval $[x, x]$ where $x^- = x^+$.

The width of an interval $[x]$ is given by:

$$w([x]) = x^+ - x^- \quad (2)$$

The mid-point of $[x]$ is given by:

$$mid([x]) = \frac{x^+ + x^-}{2} \quad (3)$$

The radius of $[x]$ is defined by:

$$rad([x]) = \frac{x^+ - x^-}{2} \quad (4)$$

2.2 Operations on intervals

The elementary mathematical operations have also been extended to intervals. The operation result between two intervals is an interval containing all the operations results of all pairs of numbers in the two intervals. So, if we have two intervals $[x] = [x^-, x^+]$ and $[y] = [y^-, y^+]$ and a law $\circ \in \{+, -, \cdot, / \}$, we can write:

$$[x] \circ [y] = \{x \circ y \mid x \in [x], y \in [y]\} \quad (5)$$

2.3 Interval system

Uncertain parameters in systems can be bounded by intervals, one obtains interval systems. A SISO interval system denoted $[G](s, [p], [q])$ is a family of systems:

$$[G](s, [p], [q]) = \left\{ \frac{\sum_{j=0}^m [q_j] s^j}{\sum_{i=0}^n [p_i] s^i} \mid [q_j] = [q_j^-, q_j^+], [p_i] = [p_i^-, p_i^+] \right\} \quad (6)$$

with: $[q] = [[q_1], \dots, [q_n]]$ and $[p] = [[p_1], \dots, [p_n]]$ are two vectors of uncertain parameters and s the Laplace variable.

3. COMPUTATION OF THE CONTROLLER

In this section, we aim to derive a robust control law by combining the previous interval analysis with linear theory of control. In this paper, we particularly use the direct synthesis control method. Indeed, the controller computation is based on the model and on the wanted closed-loop transfer. The proposed approach allows an ease of computation and a (low-)order controller which is adapted for embedded real-time microsystems where the sampling time are often less than $0.5ms$.

3.1 Closed-loop scheme

Consider the closed-loop control of an interval system $[G](s, [a])$ as depicted in [Fig. 1](#). $[C](s)$ is the controller to be computed. Let $[H](s, [b])$ be the interval closed-loop.

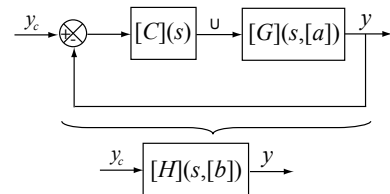

Fig. 1. A closed-loop system.

3.2 Definition of the different transfers

The main objective of this paper is to design robust control law for uncertain models with zero-order numerator. Let us consider the following system with zero-order numerator:

$$[G](s, [a]) = \frac{1}{\sum_{i=0}^n [a_i] s^i} \quad (7)$$

Such as: $[a] = [[a_0], \dots, [a_n]]$ is a box of interval parameters.

We also assume an interval reference model $[H](s, [b])$ that defines the closed-loop behavior as follows:

$$[H](s, [b]) = \frac{1}{\sum_{j=0}^m [b_j] s^j} \quad (8)$$

Where $[b] = [[b_0], \dots, [b_m]]$ is a box of interval parameters.

3.3 Direct synthesis of the controller

The computation of the controller $[C](s)$ is based on the wanted closed-loop transfer $[H](s, [b])$ (derived from some given specifications) and on the interval model $[G](s, [a])$.

According to Fig. 1, we have:

$$[H](s, [b]) = \frac{1}{1 + \frac{1}{[C](s)[G](s, [a])}} \quad (9)$$

From (9), we derive the interval controller $[C](s)$:

$$[C](s) = \frac{1}{[G](s, [a]) \left(\frac{1}{[H](s, [b])} - 1 \right)} \quad (10)$$

As the controller contains $1/[G](s, [a])$, the method can be classified as a compensation technique.

Introducing (8) in (10) and replacing $[G](s, [a])$, we get:

$$[C](s, [a], [b]) = \frac{\sum_{i=0}^n [a_i] s^i}{\sum_{j=0}^m [b_j] s^j - 1} \quad (11)$$

The causality of the controller is ensured when $m \geq n$.

Note that, there exists a set of controllers inside the interval controller defined in (11) that guarantee the required performances. However, if the specified performances are too severe or the width of the parameters of the interval model is too large, the set of controllers ensuring performances may be reduced. Moreover, any point controller chosen for the implementation should be validated using a performances analysis based on H_∞ approach.

3.4 Controller validation

The aim of this part consists to validate *a posteriori* that a given controller ensures the imposed performances. The idea consists to demonstrate that this controller ensures the specified performances for any system inside the interval model, i.e $\forall G(s) \in [G](s, [a])$. This demonstration will be performed via H_∞ approach.

The H_∞ synthesis consists to compute a controller ensuring H_∞ performances. The required performances are

transcribed into weighting functions during the synthesis. According to the standard H_∞ problem (Balas et al. (2001)), the computed controller must satisfy:

$$\|F_l(K(s), P(s))\|_\infty \leq \gamma \quad (12)$$

where $F_l(K(s), P(s))$ is the transfer function of the interconnection between an augmented system $P(s)$ and the controller to be designed $K(s)$. The augmented system $P(s)$ includes the system to be controlled $G(s)$ and the weighting functions $W_i(s)$ describing the specifications.

In our case, the controller is known: $K(s) = C(s) \in [C](s)$. The system is known but it is an interval: $[G](s, [a])$. Since the system is interval, the augmented plant will also be an interval $[P](s)$. Our objective is now to verify that:

$$\|F_l(K(s), [P](s))\|_\infty \leq \gamma \quad (13)$$

If γ is close to one, $K(s)$ is valid and ensures the performances for the entire interval system $[G](s, [a])$.

4. MODELING AND CONTROL OF PIEZOACTUATORS

This section is focused on the application of the proposed method to control piezoactuators used in microgrippers. We particularly use unimorph piezocantilevers due to their ease of fabrication relative to multimorph ones. A unimorph piezocantilever is made up of a piezoelectric layer (often Lead-Zirconate-Titanate (PZT) ceramic) and one passive layer (often Copper or Nickel). When a voltage U is applied to the piezolayer, it expands/contracts resulting a global deflection δ of the cantilever (see Fig. 2).

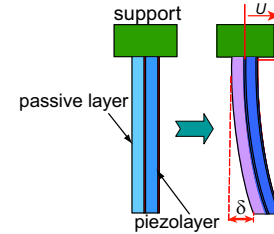

Fig. 2. Principle of a unimorph piezocantilever.

Due to their high resolution, high bandwidth and the ability to convert electrical energy into mechanical displacement or vice-versa, piezocantilevers are widely used in micro/nano-positioning applications where the displacements must be small and highly accurate. In particular, micromanipulation/microassembly tasks require ultra-fine and repeatable motions, making piezoelectric materials a suitable choice. However, these materials are very sensitive to the environment (temperature, vibrations, etc.). As a result, the required accuracy is significantly affected due to the behavior variation (varying parameters). In addition, the performances or even the stability may be lost in presence of such critical conditions. One way to model these piezocantilevers is to use transfer functions with uncertain parameters. For that, interval modeling techniques (Keel and Bhattacharyya (1994)) are introduced to characterize the uncertain parameters. Afterwards, we apply the proposed controller design to enhance their performances.

The interval model $[G](s, [a])$ can be derived using a set of piezocantilevers having nearly the same dimensions.

Despite their similarity in dimensions, small differences of some microns (due to the imprecision of the microfabrication process) yield non-negligible differences on their model parameters. So, instead of having a model of one piezocantilever with time-varying parameters during the experiment, we use two piezocantilevers with different parameters. Then, from the two derived models of piezocantilevers, we define one interval model used to design controller ensuring performances not only for the both piezocantilevers but also for a set of piezocantilevers having models inside the interval model $[G](s, [a])$.

4.1 Presentation of the setup

The experimental setup as in Fig. 3 is composed of:

- two unimorph piezocantilevers having a total width of 2mm, a length of 15mm and a thickness of 0.3mm.
- a computer-DSPACE hardware and the Matlab-Simulink software used for the data-acquisition and control,
- an optical sensor (Keyence LC-2420) with 10nm of resolution used to measure the deflection.
- and a high-voltage (HV: $\pm 200V$) amplifier,

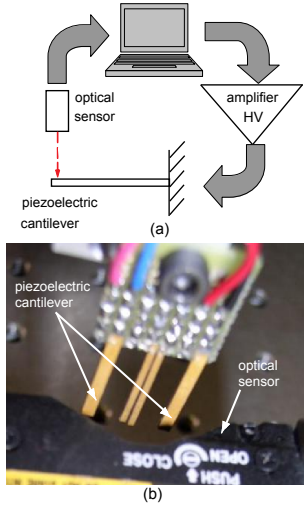

Fig. 3. A photograph of the experimental setup.

4.2 Identification of the piezocantilevers models

According to the works in Haddab et al. (2000), the linear relation that relates the input voltage U applied to a piezocantilever, the force F applied to the piezocantilever at its tip and the resulting deflection δ (see Fig. 4) can be written as follows:

$$\delta = (d_p U + s_p F) D(s) \quad (14)$$



Fig. 4. A piezocantilever under external excitations.

where $s_p > 0$ is the elastic constant of the piezocantilever, $d_p > 0$ is the piezoelectric constant and $D(s)$ represents the dynamic part of the piezocantilever (with $D(0) = 1$).

In this paper, we assume that the force $F = 0$. As a result the resulting deflection at the tip of a piezocantilever when an input voltage U is applied to its electrodes can be defined by the linear relation as follows:

$$\delta = d_p D(s) U = G(s) U \quad (15)$$

where $G(s)$ represents the model of piezocantilever.

Let $G_1(s)$ and $G_2(s)$ be the models of the two piezocantilevers. In this contribution, we are interested to the first mode (resonance). For that, a second order model was chosen for each piezocantilever. Using the output error method and the matlab software, we obtain:

$$G_1(s) = \frac{1}{9.8 \times 10^{-8} s^2 + 7.406 \times 10^{-6} s + 1.439} \quad (16)$$

$$G_2(s) = \frac{1}{8.777 \times 10^{-8} s^2 + 7.926 \times 10^{-6} s + 1.284}$$

4.3 Derivation of the interval model

Let us rewrite each model $G_i(s)$ ($i = 1, 2$) as follows:

$$G_i(s) = \frac{1}{a_{2i} s^2 + a_{1i} s + a_{0i}} \quad (17)$$

The interval model $[G](s, [a])$ is therefore derived using the two point models $G_i(s)$. Considering each parameter of $G_1(s)$ and the corresponding parameter in $G_2(s)$ as an endpoint of the interval parameter in $[G](s, [a])$, we have:

$$[G](s, [a]) = \frac{1}{[a_2] s^2 + [a_1] s + [a_0]} \quad (18)$$

such as:

$$\begin{aligned} [a_2] &= [\min(a_{21}, a_{22}), \max(a_{21}, a_{22})] = [8.777, 9.8] \times 10^{-8} \\ [a_1] &= [\min(a_{11}, a_{12}), \max(a_{11}, a_{12})] = [7.4, 7.926] \times 10^{-6} \\ [a_0] &= [\min(a_{01}, a_{02}), \max(a_{01}, a_{02})] = [1.284, 1.439] \end{aligned}$$

In order to increase the stability margin of the closed-loop system and to ensure that the interval model really contains the models (16), we propose to extend the intervals of the model (18). However, when the interval width of the parameters in the model is too large, it is difficult to find a controller that respects both the stability and performances of the closed-loop. After some trials of controller design, we choose to expand the interval width of each parameter of (18) by 10%. 10% is the maximal value allowed in this application. Finally, the extended parameters of the interval model are given as follows:

$$\begin{aligned} [a_2] &= [8.725, 9.851] \times 10^{-8} \\ [a_1] &= [7.38, 7.952] \times 10^{-6} \\ [a_0] &= [1.276, 1.446] \end{aligned} \quad (19)$$

4.4 Computation of the interval reference model

We want to satisfy the following specifications for the closed-loop:

- no overshoot,
- settling time: $15ms \leq tr_{5\%} \leq 30ms$,
- static error: $|\varepsilon| \leq 1\%$.

From the condition on the causality of the controller, i.e. $m \geq n$, a 2^{nd} order transfer is chosen for $[H]$. Since, the wanted behavior of the closed-loop is without overshoot, we take the following structure for $[H]$:

$$[H](s, [b]) = \frac{[K_p]}{([\tau]s + 1) \left(\frac{[\tau]}{100}s + 1 \right)} \quad (20)$$

Such as:

- $[b] = [[K_p], [\tau]]$
- $[K_p] = 1 + \varepsilon = [0.99, 1.01]$,
- $[\tau] = \frac{tr_{5\%}}{3} = [5ms, 10ms]$.

4.5 Computation of the interval controller

Based on (11), the interval controller transfer is given by:

$$[C](s, [a], [b]) = \frac{[a_2]s^2 + [a_1]s + [a_0]}{0.01 \frac{[\tau]^2}{[K_p]} s^2 + 1.01 \frac{[\tau]}{[K_p]} s + \frac{1}{[K_p]} - 1} \quad (21)$$

After numerical application, we obtain:

$$[C](s) = \frac{[8.725, 9.851] \times 10^{-8} s^2 + [7.38, 7.952] \times 10^{-6} s + [1.276, 1.446]}{[0.247, 1.01] \times 10^{-6} s^2 + [0.005, 0.0102] s + [-0.01, 0.01]} \quad (22)$$

5. EXPERIMENTAL RESULTS

The computed controller given in (22) is interval and is not directly implementable. It contains a set of point-controllers that guarantee the required performances. One of these point controllers must be chosen and has to be implemented. A natural choice is the mid-point controller whose the parameters are the mid-point of the interval parameters of $[C](s)$ in (22). Afterwards, a validation of this mid-point controller via H_∞ approach will be given. The so-called mid-point controller is therefore:

$$C_{mid}(s) = \frac{0.09288s^2 + 7.666s + 1.362 \times 10^6}{s(0.6285s + 7600)} \quad (23)$$

To validate this controller (23), the method presented in 3.4 will be used. In our case, the interval system $[G](s, [a])$ and the controller $K(s) = C_{mid}(s)$ are known. Finally, the wanted performances already detailed in 4.4 can be transcribed into a weighting function $W_1(s)$.

Fig. 5-a presents the closed-loop scheme augmented by the weighting function $W_1(s)$. Its corresponding standard scheme is shown in Fig. 5-b.

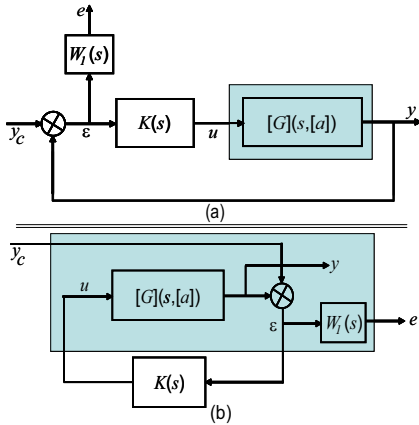

Fig. 5. Schemes of the augmented closed-loop and of the standard form.

From Fig. 5, we have:

$$F_l(C_{mid}(s), [P](s)) = W_1(s)[S](s) \quad (24)$$

where $[S](s) = (1 + C_{mid}(s)[G](s, [a]))^{-1}$ represents the interval sensitivity function.

Using (13) and (24), we obtain the following problem:

$$\|W_1(s)[S](s)\|_\infty \leq \gamma \quad (25)$$

which can be satisfied if:

$$|[S](s)| \leq \left| \frac{\gamma}{W_1(s)} \right| \quad (26)$$

If the latter is satisfied, we have:

$$\|[S](s)\|_\infty \leq \left\| \frac{\gamma}{W_1(s)} \right\|_\infty \quad (27)$$

To transcribe the specifications in 4.4 into weighting $W_1(s)$, we choose the following structure:

$$W_1(s) = \frac{\frac{1}{w_p} s + 1}{\frac{|\varepsilon|}{w_z} s + |\varepsilon|} \quad (28)$$

where $w_z = \frac{3}{tr + \sqrt{\left(\frac{1}{|\varepsilon|}\right)^2 - 1}}$ and $w_p = w_z \sqrt{\left(\frac{1+D\%}{|\varepsilon|}\right)^2 - 1}$

$D\%$ represents the overshoot. We therefore have:

$$\left\| \frac{1}{W_1(s)} \right\|_\infty = \left\| \frac{s+1}{s+100} \right\|_\infty = 1 \quad (29)$$

Next step consists to compute $\|[S](s)\|_\infty$ which is an interval. For an interval system the maximal H_∞ norm of its sensitivity function is achieved at twelve Kharitonov vertices Wang (2002). Based on this result, the H_∞ norm of the sensitivity is therefore obtained: $\|[S](s)\|_\infty = 1.024$.

Finally, we deduce from (27) that $\gamma \approx 1.024$ which is close to one, meaning that the chosen controller $C_{mid}(s)$ can ensure the performances.

A comparison between the magnitudes of $\frac{1}{W_1(s)}$ and of the sensitivity function is also performed in order to prove that the inequality (26) is satisfied. The obtained results in Fig. 6 prove that the singular values of $[S](s)$ is effectively almost bounded by that of $\frac{1}{W_1(s)}$, and consequently the specified performances are ensured by the mid-point controller.

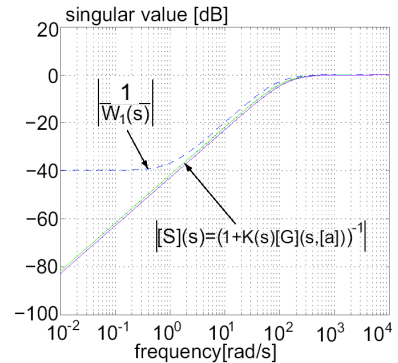

Fig. 6. Singular values of $[S](s)$ and of $\frac{\gamma}{W_1(s)}$

The mid-point controller (23) is applied to both piezocantilevers. Indeed, a step reference of $20\mu m$ is applied to the

closed-loops. Fig. 7 shows the experimental results compared with the envelope of the desired behavior $[H](s, [b])$. We especially mean by the envelope of $[H](s, [b])$, all step responses between the step responses of $H_1(s)$ and $H_2(s)$, the first one being with minimal time constant $\tau = 5ms$ and maximal static gain $K = 1.01$ while the second one being with maximal time constant $\tau = 10ms$ and minimal static gain $K = 0.99$. As shown on the figure, the controller has played its role and satisfied the required specifications. Indeed, experimental settling times are about $tr_1 = 20.3ms$, $tr_2 = 21.8ms$ respectively for the piezocantilevers 1 and 2, and the experimental static errors are neglected and belong to the specified interval $|\varepsilon| \leq 1\%$.

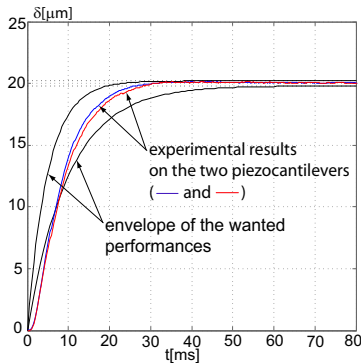

Fig. 7. Step response of the closed-loop: experimental results with $C_{mid}(s)$ and the envelope of $[H](s, [b])$.

6. CONCLUSION

In this paper, the interval modeling and robust controller design for piezoactuators were proposed. Due to its simplicity and natural way to model uncertain parameters, intervals were used to bound the uncertainties. The approach is valuable for zero-order numerator models which are sufficient to account the behaviors of piezoelectric cantilevers. To derive the controller, we combined the interval arithmetic with a linear control theory. The implemented controller was validated using the H_∞ approach. The experimental results on two piezoactuators also proved the efficiency of the proposed method. Future works concern the extension of the proposed approach to generalized models, i.e. not limited to zero-order numerator ones.

REFERENCES

- Devasia, S., Eleftheriou, E.E., and Moheimani, R. (2007), "A survey of control issues in nanopositioning," *IEEE Trans. on Control System Technology (T-CST)*, Vol.15, 802-823.
- Haddab, Y., Chaillet, N., and Bourjault, A. (2000), "A microgripper using smart piezoelectric actuators," *IEEE/RSJ International Conference on Intelligent Robot and Systems (IROS)*, Takamatsu-Japan.
- G. Bining, C. F. Quate and Ch. Berger (1986), "Atomic Force Microscope," *Physical Review Letters* Vol.56, 930-933.
- Micky Rakotondrabe, Yassine Haddab and Philippe Lutz, "Development, Modeling, and Control of a Micro/Nanopositioning 2-DOF Stick-Slip Device," *IEEE-Trans. on Mechatronics (T-mech)*, Vol.14, Issue 6, 733-745, December 2009.
- Rakotondrabe, M., Clévy, C. and Lutz, P. (2010), "Complete open loop control of hysteretic, creeped and oscillating piezoelectric cantilever," *IEEE-Trans. on Automation Science and Engineering (T-ASE)*, 7(3), 440-450.
- Rakotondrabe, M., Haddab, Y. and Lutz, P. (2009a), "Quadrilateral modelling and robust control of a nonlinear piezoelectric cantilever," *IEEE-Trans. on Control Systems Technology (T-CST)*, Vol.17, 528-539.
- Takaba, K. (1998), "Robust H_2 control of descriptor system with time-varying uncertainty," *International Journal of Control (IJC)*, Vol.71, 559-579.
- Su, H., Wang, J., Yu, L. and Chu, J. (1998), "Robust H_∞ controller design for time-varying uncertain linear systems with time-varying state and control delays," *International Journal of Systems Science*, Vol.29, 863-872.
- Moore, R.E. (1966), "Interval Analysis," Prentice-Hall, Englewood Cliffs N. J.
- Jaulin, L., and Walter, E. (1993), "Set inversion via interval analysis for nonlinear bounded-error estimation," *Automatica*, Vol.29, 1053-1064.
- Jaulin, L., Kieffer, M., Didrit, O., and Walter, E. (2001), "Applied Interval Analysis," Springer, Verlag London.
- Jaulin, L., and Walter, E. (1994), "Guaranteed characterization of stability domains via set inversion," *IEEE Trans. on Automatic Control*, Vol.39, 886-889.
- V.L. Kharitonov (1978), "Asymptotic stability of an equilibrium position of a family of systems of linear differential equations," *Differential'nye Uravneniya*, 14, 2086-2088.
- Smagina, Y., and Brewerb, I. (2002), "Using interval arithmetic for robust state feedback design," *Systems and Control Letters*, Vol.46, 187-194.
- Bondia, J., Kieffer, M., Walter, E., Monreal, J., and Picto, J. (2004), "Guaranteed tuning of PID controllers for parametric uncertain systems," *IEEE Conference on Decision and Control (CDC)*, 2948-2953.
- Li, K., and Zhang, Y. (2009), "Interval Model Control of Consumable Double-Electrode Gas Metal Arc Welding Process," *IEEE - Transactions on Automation Science and Engineering (T-ASE)*, 1-14.
- C.-T. Chen and M.-D. Wang (2000), "A two-degrees-of-freedom design methodology for interval process systems," *Computers and Chemical Engineering*, 23,1745-1751.
- Khadraoui S., Rakotondrabe M. and Lutz P., (2010), "Robust control for a class of interval model: application to the force control of piezoelectric cantilevers," *IEEE-CDC*, (Conference on Decision and Control), accepted, Atlanta Georgia USA.
- Balas, G. J., Doyle, J. C., Glover, K., Packard, A. and Smith, R. (2001), " μ -synthesis and synthesis toolbox," The Mathworks User's Guide-3.
- Wang, L. (2002), " H_∞ Performance of Interval Systems," eprint arXiv:math/0211013, Vol.1, 1-8.
- Keel, L. H., Bhattacharyya, S. P. (1994), "Control system design for parametric uncertainty," *International Journal of Robust and Nonlinear Control*, Vol.4, 87-100.