

Combining self-sensing with an Unknown-Input-Observer to estimate the displacement, the force and the state in piezoelectric cantilevered actuators

Micky RAKOTONDRABE, *Member, IEEE*

Abstract—Self-sensing techniques is defined as the use of an actuator as a sensor at the same time. The main advantage of such techniques is the embeddability and the packageability of the systems. This paper deals with the development of a self-sensing technique able to estimate the displacement, the force and the state in piezoelectric cantilevered actuators. The main novelties relative to previous works are: 1) three signals (displacement, force and states) are provided at the same time instead of only two (displacement and force), 2) and these three signals are provided in a complete way, i.e. low and high frequency information can be provided (instead of exclusively low or high frequency). It is therefore possible to further use the measurement for a displacement control or for a force control by using the output feedback methods or by using modern control methods (state-feedback). In order to allow such measurement possibilities, the proposed approach consists in combining an unknown-input-observer (UIO) with the classical electrical circuit of a self-sensing. The experimental results confirm the effectiveness of the proposed approach.

I. INTRODUCTION

Self-sensing consists in using an actuator as a sensor at the same time. This is possible for reversible systems such as piezoelectric materials and magnetic systems. In piezoelectric materials, this reversibility of physical principle is given by the direct (1) and the converse (2) effects: (1) mechanical stress provokes the apparition of electrical charges on the material's surface, (2) and an electrical field provokes the deformation of the material. Consequently, the electrodes used to supply the piezoelectric actuators can also be used to recuperate the appearing charges. The principle of a self-sensing consists in using an electrical circuit that amplifies these charges and transforms them into an exploitable voltage, and then using a convenient observer that traces back and estimates the deformation (displacement) or the stress (force). This observer is based on the model of the piezoelectric actuator and on the model of the electrical circuit. Both the electrical circuit and the observer compose the self-sensing measurement technique.

FEMTO-st Institute,
UMR CNRS-6174 / UFC / ENSMM / UTBM
Automatic Control and Micro-Mechatronic Systems department
(AS2M department)
25000 Besançon - France
mrakoton@femto-st.fr

The main advantage of self-sensing is that no external sensor is used to measure the signals. This advantage is very promising in systems where the available space is limited and where the embeddability of the measurement systems is essential. These systems include: MEMS, MOEMS, microsystems, microrobotics, systems for precise manipulation and precise positioning, etc.

So far, self-sensing was used to exclusively estimate the displacement or the force in vibrational functioning and then to damp the vibration in systems ([1][2][3][4] and references herein). Although these existing approaches were efficient to measure high frequency signals and related control applications, they could not provide long-term measurement (more than some seconds) of constant or low-frequency signals. In fact, due to the internal leakage of the piezoelectric materials, the appearing charges cannot be maintained to be constant for more than some seconds and then the accuracy of the estimation is quickly lost if the signal is not varying. This fact, additionally to the fact that exclusively the displacement or the force is available, is not congruent with the requirements in some applications such as precise positioning and precise manipulation. Indeed, during the positioning that may last several minutes, it is important that the actuators maintain the objects to be positioned with a constant force. To satisfy these requirements, a scheme of self-sensing able to measure the displacement and the force at the same time for more than 600s has been proposed in our previous work [5]. The technique could measure the displacement both in low and high frequency, but the measurement of the force was limited to low frequency or constant value. Consequently, the self-sensing can be used in a displacement feedback control with a display of the steady-state value of the force. However, force feedback control, which is also essential in micromanipulation applications, was not possible. In fact, force control involves several interests in these applications: avoiding the destruction of manipulated objects, mechanical characterization of biological small objects ... This paper proposes therefore a self-sensing technique that can provide a full measurement (low and high frequency) of both the displacement and of the force. The main advantages relative to the above existing works are:

- the proposed approach furnishes both the dynamics

and the steady-state (low and high frequency) not only for the displacement, but also for the force. This is necessary for force feedback control,

- additionally to the displacement and the force signals, the approach also provides an estimate of the whole state information of the piezoelectric actuators. Therefore, the proposed measurement technique can also be used in state feedback control of the piezoelectric actuators.

To reach these performances, the approach proposed in this paper consists in using an unknown-input-observer (UIO) technique as the observer of the self-sensing. An unknown-input-observer consists in considering a perturbation that acts to a system as an unknown input. Then a full model is used to construct the observer that will estimate not only the state of the system but also this unknown input. In the case of a piezoelectric actuator, we consider the force as the unknown input. There are several techniques of UIO according if the system's model is linear [6][7], with uncertainties [8], SISO (single-input-single-output) [9][10], MIMO (multi-input-multi-output) systems [11][12], with noises [13], or nonlinear [14], etc. A main interest of an UIO is that no additional sensor is required to provide the measurement of a perturbation or of the unknown input, assuming that a convenient model is available. The introduction of an UIO in a self-sensing technique consequently increases the possibility of the latter: increase of the number of estimated signals, amelioration of the quality of the information (static and dynamics, or low and high frequency).

The paper is organized as follows. First, we remind in section-II the previous work on self-sensing which can provide the displacement in high and low frequency and the force in low frequency. Section-III is devoted to the new self-sensing scheme which is based on an unknown-input-observer and which can provide full information (low and high frequency) on displacement, force and state. Finally, we present the experimental results in section-IV.

II. REMIND OF THE SELF-SENSING TECHNIQUE FOR THE DISPLACEMENT (LOW AND HIGH FREQUENCY) AND FORCE (LOW FREQUENCY)

This section reminds the self-sensing technique developed in our previous work [5] and that can provide a measurement of the displacement in high and low frequency and a measurement of the force only in low frequency. An UIO will be introduced to this technique afterwards (in the next section) in order to estimate the displacement, the force and the state, all in a full way (i.e. low and high frequency).

A. The piezoelectric actuator and the different signals

Let Fig. 1 presents a piezoelectric cantilevered actuator manipulating an object for precise positioning or precise manipulation (micromanipulation). In the figure, U is the input (control) voltage that makes the actuator

bends, y is the deflection (or displacement) and F is the (manipulation) force applied by the actuator's tip to the object. Thanks to a self-sensing technique, it is possible to estimate the force and the displacement without sensor.

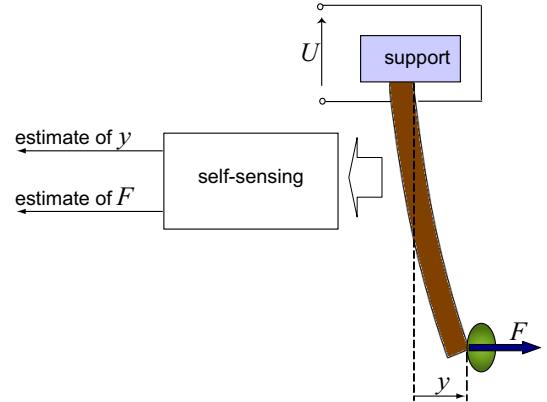

Fig. 1. Principle of a piezoelectric actuator manipulating or positioning an object.

B. Electrical scheme and observer of the self-sensing

When the piezoelectric actuator bends, electrical charge Q appears on its electrodes. This charge can be amplified by an electrical circuit and transformed into an exploitable voltage U_o . From the available signals U and U_o , an observer provides signals \hat{y} and \hat{F}_s that are the estimate of the displacement y and the estimate of the force F respectively. While the estimate \hat{y} gives a complete information (static and dynamics) of the displacement, the estimate \hat{F}_s only gives static information (low frequency or steady-state) of the force. The self-sensing is composed of two parts: 1) the electrical circuit, 2) and an observer. The observer itself is composed of a static displacement and force observer and of a dynamic observer. Fig. 2-a presents the principle scheme of the self-sensing and Fig. 2-b presents the electrical circuit used. Remind that the electrical circuit is a charge amplifier or integrator. The static displacement and force observer provides a 'static' information (low frequency) of the two signals while the dynamic observer provides the complete information (static and dynamics, or low and high frequency) of the displacement. In the figure, C_r is a "reference capacitor" used to "absorb" a significant part of charge due to the applied voltage. The value of C_r is chosen to be close to the equivalent capacitor of the piezoelectric actuator. In fact, charge due to the input voltage U also appears on the electrodes additionally to the charge due to the bending. Consequently, C_r allows to cancel the charges due to the voltage U in order to finally have the charge due to the deformation. The capacitor C is used for the integrator while R_{disc} and relay k_{disc} allow resetting the output U_o if saturated.

Finally the amp-op is considered to have a very high input impedance.

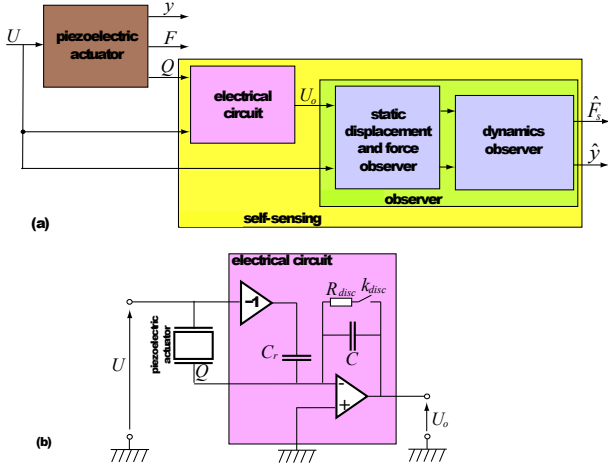

Fig. 2. Complete self-sensing [5]: (a) - principle scheme. (b) - electrical circuit used.

Based on the modeling of the actuator and of the electrical circuit, the estimate steady-state force \hat{F}_s and the estimate complete information (steady-state and dynamics) of the displacement \hat{y} are described by the following observer equations [5]:

$$\left\{ \begin{array}{l} \hat{F}_s(t) = \\ \frac{1}{\beta} \left((C_r U(t) - C U_o(t)) - F_{cr}(t) - F_{hys}(t) - \frac{1}{R_{fp}} \int_0^t U dt \right) \\ \hat{y}_s^{free}(t) = \\ \frac{1}{\alpha} \left((C_r U(t) - C U_o(t)) - Q_{DA}(t, U) - \frac{1}{R_{fp}} \int_0^t U dt \right) \\ \hat{y}(s) = \left(\frac{G_1(s)}{G_2(s) + G_3(s)} \right) \hat{y}_s^{free}(s) - s_p \hat{F}_s(s) \end{array} \right. \begin{cases} \Gamma(U, y) \\ = \sum_{i=1}^{n_h} w_{hi} \cdot \max \{U(t) - r_{hi}, \min \{U(t) + r_{hi}, y_i(t - T)\}\} \\ \Gamma(U, y)(t = 0) = \Gamma_0 \end{cases} \quad (3)$$

where n_h is the number of backlashes, parameters w_{hi} and r_{hi} are the weighting and the threshold of the i^{th} backlash, y_i is the elementary output (i.e. output of the i^{th} backlash) and finally T_s represents the sampling period.

The creep operator $F_{tfc}(s)$ is described by a transfer function:

$$F_{tfc}(s) = \frac{\sum_{k=0}^m b_k s^k}{\sum_{l=0}^n a_l s^l} \quad (4)$$

where parameters b_k and a_l are coefficients of the transfer and m and n ($m \leq n$) are the degrees of the polynomials.

G_1 , G_2 and G_3 are called gains of the dynamic observer. Fig. 3 pictured the block diagram of the observer defined by (Eq. 1). The identification and computation of all the parameters are described in [5].

where β is the force sensitivity coefficient that relates the electrical charge on the actuator's surface with the applied external force, α is the actuator charge-displacement coefficient. Coefficient s_p is the piezoelectric compliance that relates the displacement with the applied external force. Signal \hat{y}_s^{free} corresponds to the estimate steady-state displacement when no external force is applied (free bending). Resistor R_{fp} is a leakage resistor of the piezoelectric actuator and $Q_{DA}(t, U)$ is its dielectric absorption. This dielectric absorption can be represented by a first order transfer $Q_{tfdA}(s)$ with a static gain k_{DA} and a constant time τ_{DA} , s being the Laplace variable. Transfer function $D(s)$ is the dynamics of the piezoelectric actuator such as $D(s = 0) = 1$. Transfer function $H(s)$ is the transfer that relates the input U with the exploitable voltage U_o . This is linear since the relation between U and Q is normally linear. Signals $F_{tfc}(t)$ and $F_{hyst}(t)$ (or $F_{tfc}(s)$ and $F_{hyst}(s)$ in the Laplace domain) capture the creep and the hysteresis nonlinearity that typify the voltage-to-displacement behavior of the piezoelectric actuator. They can be approximated by a linear transfer function $F_{tfc}(s)$ and a nonlinear operator $\Gamma(U, y)$ respectively. Concerning the hysteresis, there are several approximation approaches possible. As the Prandtl-Ishlinskii is very convenient for a real-time implementation [15][16][17][18][19], it has been used. In this, the operator $\Gamma(U, y)$ is described as the superposition of several elementary hysteresis called backlash (or play operator) as in (Eq. 3):

with

$$\left\{ \begin{array}{l} F_{cr}(s) = F_{tfc}(s)U(s) \\ F_{hys}(s) = \frac{\beta}{s_p} \Gamma(U, y) \\ Q_{DA}(s) = \frac{k_{DA}}{(1 + \tau_{DA}s)} U(s) = Q_{tfdA}(s)U(s) \\ G_1(s) = \Gamma(U, y) D(s) \\ G_2(s) = -\frac{1}{\frac{\alpha}{R_{fp}}s} - \frac{k_{DA}}{\alpha(1 + \tau_{DA}s)} - \frac{1}{\alpha} H(s) \\ G_3(s) = \frac{C_r}{\alpha} \end{array} \right. \quad (2)$$

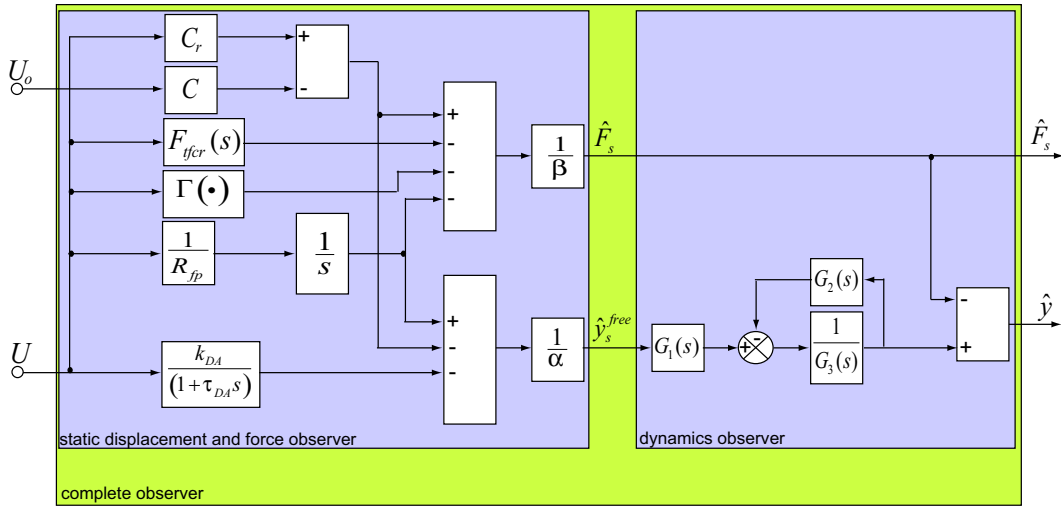

Fig. 3. Block diagram of the actual observer.

III. A NEW SELF-SENSING WITH FULL MEASUREMENT OF THE DISPLACEMENT, THE FORCE AND THE STATES

The self-sensing previously presented provides the following signals: 1) estimate of the displacement with complete information (static and dynamics, i.e. low and high frequency), 2) and estimate of the force only at its static aspect (i.e. low frequency). In this section, we propose to extend the previous self-sensing scheme in order to have the following signals:

- 1) estimate of the displacement with complete information (static and dynamics),
- 2) estimate of the force with complete information (static and dynamics),
- 3) and estimate of the whole states with complete information (static and dynamics).

A. Principle scheme of the extended complete self-sensing

We start by modeling the piezoelectric actuator. The model that relates the output deflection $y(s)$, the applied input voltage $U(s)$ and the force $F(s)$ applied by the piezoelectric actuator at its tip is [22]:

$$y(s) = (\Gamma(U, y) - s_p F(s)) D(s) \quad (5)$$

where s_p , $D(s)$ and $\Gamma(U, y)$ are the parameters and operator already introduced above.

It is noticed that $-F(s)$ is the force applied by the environment (e.g. manipulated object) to the actuator. Analyzing (Eq. 5), we deduce that the actuator is equivalent to a system with two inputs (U and $-F$) and one output (y). The problem comes now to the estimation of the displacement y and of the unknown input $-F$ (or F). Considering that the estimate \hat{y} of the displacement is already available thanks to the self-sensing developed in the previous section and to its observer which are pictured in Fig. 3, there remain the estimation of the force in a complete way and the estimation of the states. However, according to Fig. 3, the displacement estimation requires the availability of the force. We therefore

propose to use the estimate force for that end when this estimate is available from the new proposed observer. The observer used for the force is called an unknown input observer (UIO) since F to be estimated is now considered as an input of the actuator.

To resume, the available signals are: 1) the input control U , 2) and the estimate \hat{y} of the displacement issued from the previous self-sensing, subjected that there is a way to know the force.

Let us propose the following extended observer scheme which is made up of several *sub-observers*:

- First a classic (sub)observer is constructed. This classic observer, called state observer, has at its input the available signals U , \hat{y} (estimate displacement from the self-sensing) and \hat{F} (subjected that there is an estimator for the force). The state observer gives at its output the estimate state \hat{x} and another estimate displacement denoted $\hat{\hat{y}}$.
- Then, the second (sub)observer is a force observer that has as input the newly available signal \hat{x} , the input control U and the initial estimate displacement \hat{y} from the self-sensing.
- Finally, the latter estimate force \hat{F} is used as one input of the state observer and of the displacement observer.

Fig. 4 resumes the systemic and principle scheme of the actuator with the proposed extended self-sensing. We can remark from this figure the extension of the initial observer pictured in Fig. 3.

B. An UIO observer for the force and state estimation

1) *Problem statement:* In this sub-section, we present the state and force observers. For that, an unknown input observer (UIO) is used since one of the objective is to estimate $-F$ (and thus F) which is an input. From (Eq. 5), it is still possible to find a transformation in order to have a state-space representation defined by:

$$\begin{aligned}\dot{x} &= Ax + \Gamma(U, y) + BF \\ y &= Cx\end{aligned}\quad (6)$$

where $x \in R^n$ denotes the state vector, $A \in R^{n \times n}$ is the state matrix, $C \in R^{1 \times n}$ is the output matrix (a vector) and $B \in R^n$ is called disturbance input matrix.

The following assumptions are made:

- the matrices A , B and C are known,
- B has a full column rank,
- (A, C) is observable.

The objective is to simultaneously estimate x and F from the known signals U and \hat{y} .

2) *Equations of the observers:* Let the equation of the state observer be:

$$\begin{aligned}\dot{\hat{x}} &= A\hat{x} + \Gamma(U, \hat{y}) + B\hat{F} + K(\hat{y} - \hat{y}) \\ \hat{y} &= C\hat{x}\end{aligned}\quad (7)$$

and let the equation of the force observer be:

$$\dot{\hat{F}} = \gamma_1 \hat{y} + \gamma_2 \dot{\hat{y}} + \lambda_1 \hat{x} + \lambda_2 \dot{\hat{x}} + \lambda_3 \Gamma(U, \hat{y}) \quad (8)$$

where

- K is the gain of the state observer,
- $\gamma_1 \in R$, $\gamma_2 \in R$, $\lambda_1 \in R^{1 \times n}$, $\lambda_2 \in R^{1 \times n}$ and $\lambda_3 \in R$ are the gains of the force observer.

To seek or compute the gains γ_i ($i \in \{1, 2\}$) and λ_j ($j \in \{1, 2, 3\}$), the inverse-dynamics-based technique proposed in [14] can be used.

3) *The inverse-dynamics-based UIO computation:*

Depending on whether there exists γ_2 or not such as $\gamma_2 CB - I = 0$, two computation schemes were proposed in [14].

First computation scheme

There exists γ_2 so that $\gamma_2 CB - I = 0$. For SISO problem, this is satisfied if and only if $CB \neq 0$. Thus:

(i) γ_2 is chosen to satisfy

$$\gamma_2 CB - I = 0 \quad (9)$$

(ii) γ_1 and K are selected such as

$$A - B(\gamma_1 C + \gamma_2 CA) - KC \quad (10)$$

is *Hurwitz*

(iii) and

$$\begin{aligned}\lambda_1 &= -(\gamma_1 C + \gamma_2 CA) \\ \lambda_2 &= 0 \\ \lambda_3 &= -\gamma_2 C\end{aligned}\quad (11)$$

Second computation scheme

Many physical systems fail to satisfy the condition required for the precedent computation scheme. Hence, if for any γ_2 one cannot satisfy $\gamma_2 CB - I = 0$, a second computation scheme was proposed.

Let B^+ be the *Penrose-Moore* inverse of B . Consider $M_e = I + B(\gamma_2 C - B^+)$ and $A_e = A - B(\gamma_1 C + B^+ A) - KC$.

If M_e is nonsingular, the gains γ_1 , γ_2 and K should be selected such as $M_e^{-1} A_e$ is *Hurwitz*. However if M_e is singular, the singular value decomposition (SVD) is used. Let:

$$\begin{aligned}M_e &= U_{M_e} \Sigma_{M_e} V_{M_e}^t \\ \Sigma_{M_e} &= \begin{bmatrix} \sigma_{M_e} & 0 \\ 0 & 0 \end{bmatrix}\end{aligned}\quad (12)$$

be the SVD of M_e , where $U_{M_e} \in R^{n \times n}$ and $V_{M_e} \in R^{n \times n}$ are unitary matrices, and $\sigma_{M_e} \in R^{n_m \times n_m}$ ($n_m \leq n$) is a positive-definite diagonal matrix.

Consider the following partition of A_e by using U_{M_e} and V_{M_e} :

$$\begin{bmatrix} A_{11} & A_{12} \\ A_{21} & A_{22} \end{bmatrix} \equiv U_{M_e} A_e V_{M_e} \quad (13)$$

Thus, K , γ_1 and γ_2 should be selected such as A_{22} and $A_{11} - A_{12} A_{22}^{-1} A_{21}$ are *Hurwitz*.

After computing the gains γ_i ($i \in \{1, 2\}$), gains λ_j ($j \in \{1, 2, 3\}$) are chosen as follows:

$$\begin{aligned}\lambda_1 &= -(\gamma_1 C + B^+ A) \\ \lambda_2 &= -(\gamma_2 C - B^+) \\ \lambda_3 &= -B^+\end{aligned}\quad (14)$$

IV. EXPERIMENTAL RESULTS

The proposed extended complete self-sensing in Fig. 4 has been implemented. The setup is pictured in Fig. 5 and is composed of:

- a piezoelectric actuator with cantilever structure and with dimensions of $15mm \times 2mm \times 0.3mm$. Such actuator is essential for the development of piezoelectric microgrippers dedicated to micromanipulation or microassembly applications [20].
- a dSPACE-board and a computer material for the data acquisition, for the observer implementation and for the control signal. MATLAB-SIMULINK is the software used for that. The sampling period is set equal to $T_s = 50\mu s$;
- a displacement optical sensor (from *Keyence*) to measure the deflection (displacement) at the tip of the actuator. It has been tuned to have a resolution of $10nm$, a precision of $\pm 100nm$ and a bandwidth of $1kHz$.
- a force sensor (from *Femtotools*) to measure the force applied by the actuator at its tip. The force sensor is fixed on a linear and precise positioning table. This table can be used to move the sensor's probe towards the actuator and thus to apply a force $-F$ to this,
- a home-made electrical circuit based on the scheme in Fig. 2-b,
- and a high voltage amplifier to amplify the input voltage U from the dSPACE-computer.

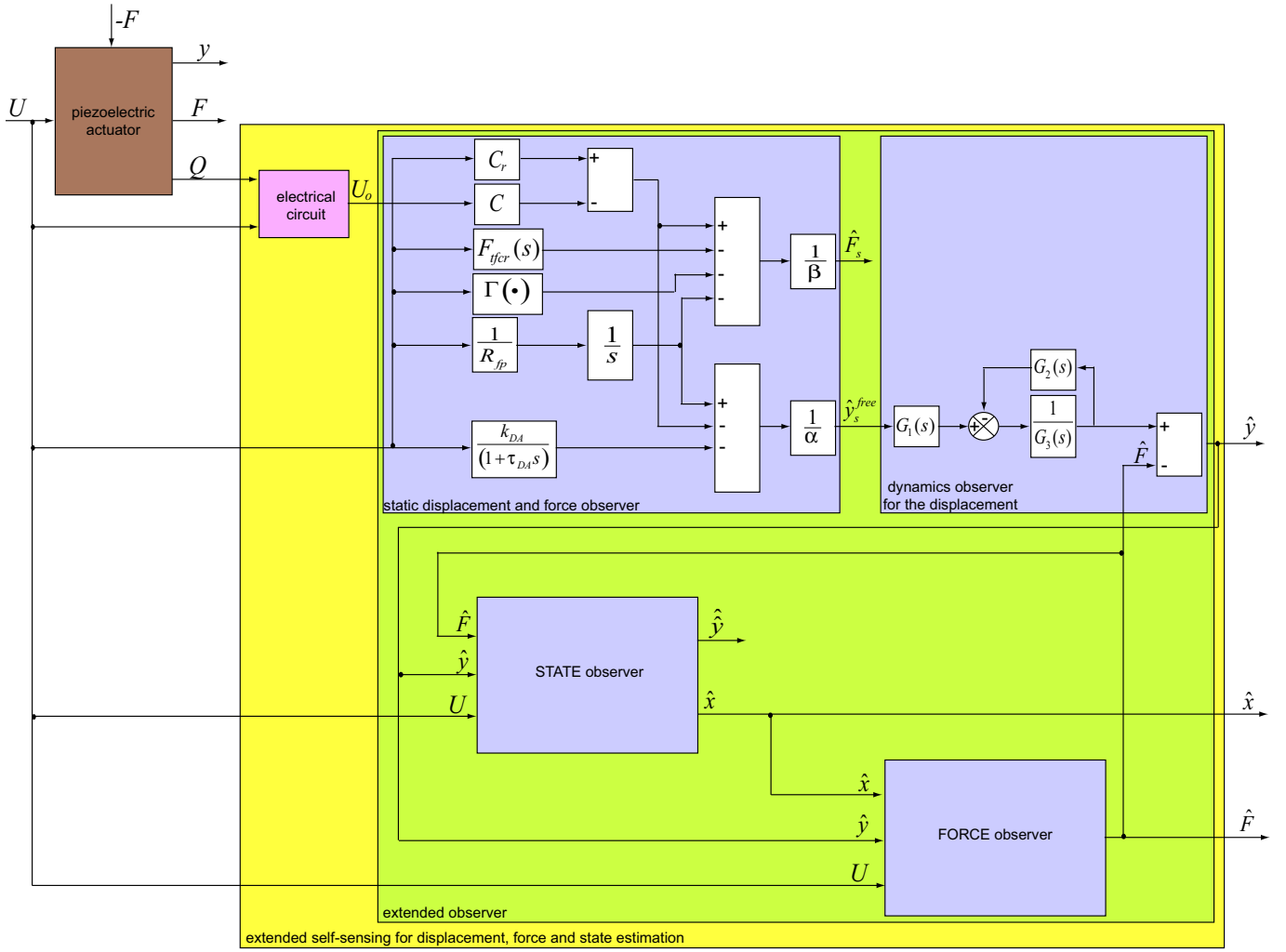

Fig. 4. Principle scheme of the extended complete self-sensing.

It is noticed that the displacement and the force sensors are used to capture the real displacement y and the real force F in order to compare them with the estimate \hat{y} and \hat{F} and thus to validate the proposed approach. During the experiment, we are not interested by the second estimate displacement \hat{y} from the state-observer since the estimate displacement \hat{y} from the dynamic observer is sufficient for any eventual application.

The parameters in (Eq. 1) (Eq. 2)(Eq. 3) are identified following the procedures in [5]. The electrical components are: $C = 47nF$ and $C_r = 8.2nF$. Finally for the given actuator, we identified and calculated $k_{DA} = -0.028\mu m/V$, $\tau_{DA} = 60s$, $\alpha = 273mV/\mu m$, $\beta = 1.03nC/mN$ and $R_{fp} = 0.435T\Omega$.

The identification of d_p and $D(s)$ is performed by applying a step voltage input to the actuator without force at the tip and by capturing the output y thanks to the optical sensor. After applying an ARMAX method

to the captured data, we obtain:

$$\begin{cases} dp = 0.690 \frac{\mu m}{V} \\ D(s) = \frac{5.752 \times 10^{-3} (s+3 \times 10^4) (s^2 - 1.9 \times 10^4 s + 3 \times 10^8)}{(s+3976) (s+54.37s+1.36 \times 10^7)} \end{cases} \quad (15)$$

At the same time, the output U_o was captured allowing the identification of $H(s)$:

$$H(s) = \frac{-0.158 (s + 5.9 \times 10^4) (s + 236) (s + 13.7)}{(s + 5.5 \times 10^4) (s + 224) (s + 12.9)} \quad (16)$$

The elastic coefficient s_p is identified by putting a known mass at the tip of the piezoelectric cantilever and by measuring the resulting deflection. We obtain: $s_p = 1.3\mu m/mN$.

The first experiment consists in applying a series of step input voltage U to the actuator when the latter is not in contact with any object or with the force-sensor. The aim is to validate the estimate \hat{y} and \hat{F} in free bending condition. Fig. 6 picture the results where Fig. 6-a represents the applied voltage. As we can see

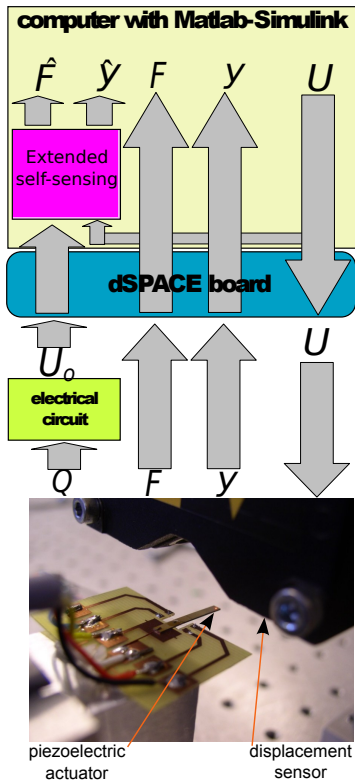

Fig. 5. The experimental setup.

in Fig. 6-b, the estimate displacement \hat{y} from the self-sensing well tracks the real displacement y measured from the optical sensor. We can also see in Fig. 6-c that the force observer provides an error ($F - \hat{F} = 0mN - \hat{F}$) bounded by $\pm 0.1mN$. This error is negligible since it is close to the sensor's accuracy itself and is greatly inferior to the range of force in the considered applications (up to ten millinewtons).

The next experiment consists in setting $U = 0V$. First we manually adjust the setup such that the actuator's tip is in slight contact with the sensor's probe but with the force still (nearly) equal to zero. Afterwards, we apply a step control to the positioning table to which the sensor is fixed. This generates a quasi step movement of the table and consequently of the sensor's probe towards the actuator. The real displacement y of the actuator due to that movement (and measured thanks to the optical sensor) and the estimate displacement \hat{y} are presented in Fig. 7-a. In parallel, the real force F (measured by the force sensor) and the estimate force \hat{F} are presented in Fig. 7-b. These figures confirm that the estimates \hat{y} and \hat{F} from the proposed self-sensing well track the real force and the real displacement respectively in their static (steady-state) and dynamics (transient part) aspects.

V. CONCLUSION

This paper presented a self-sensing approach to estimate the complete information (static and dynamics aspect, or low and high frequency) of the displacement, of the force and of the states in piezoelectric actuators. The proposed approach is essential for displacement control and force control of piezoelectric actuators where it is difficult to use sensors. The applications include precise positioning, precise manipulation, MEMS, MOEMS, microsystems and microrobotics. To reach the objectives, we proposed to introduce an unknown input observer (UIO) in an existing self-sensing approach. The main advantages are 1) the possibility of feedback control for

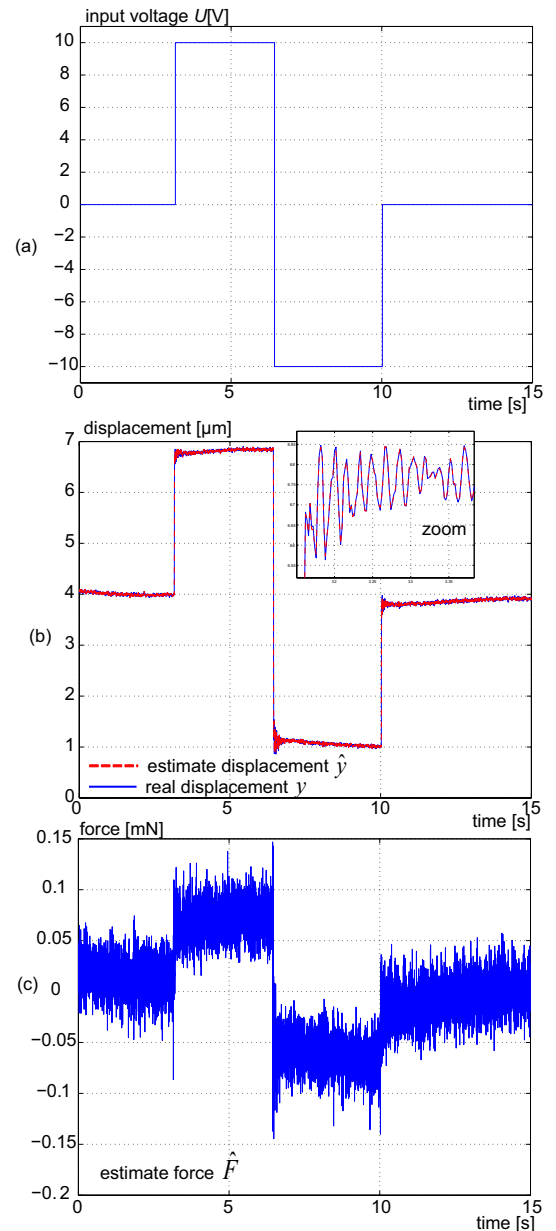

Fig. 6. Experimental validation with $F = 0mN$ (actuator in free condition).

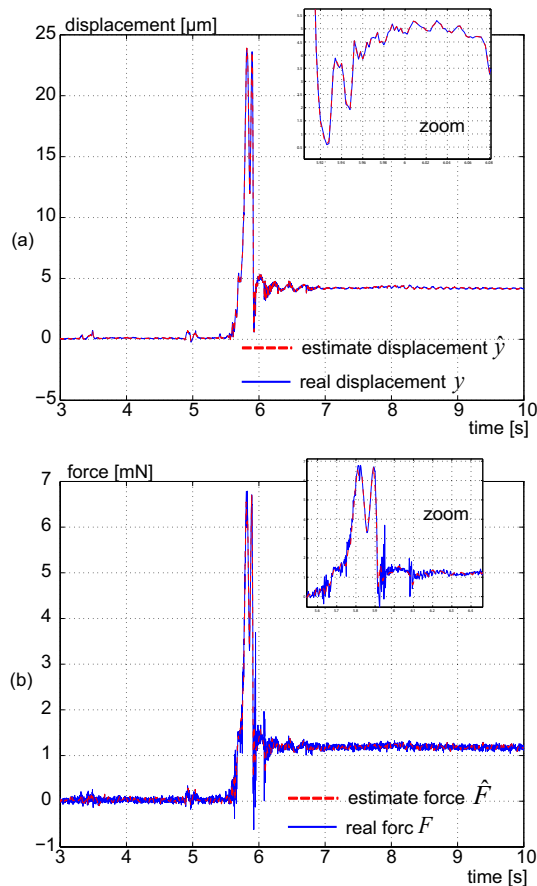

Fig. 7. Experimental validation with $F \neq 0mN$ (actuator in contact with the force sensor).

the displacement and for the force, 2) and the possibility to use modern control such as state-feedback. Finally the proposed scheme inherits the general advantage of self-sensing that is the embeddability of the measurement technique.

ACKNOWLEDGMENT

This work is supported by the national ANR-Emergence MYMESYS-project (ANR-11-EMMA-006: High Performances Embedded Measurement Systems for multiDegrees of Freedom Microsystems).

REFERENCES

- [1] J.J. Dosch, D.J. Inman and E. Garcia, "A Self-Sensing Piezoelectric Actuator for Collocated Control", *Journal of Intell. Mater. Syst. and Struct.*, vol 3, pp. 166-185, 1992.
- [2] T. Takigami, K. Oshima, Y. Hayakawa and M. Ito, "Application of self-sensing actuator to control of a soft-handling gripper", *Proc. to IEEE ICCA*, pp. 902-906, Italy, 1998.
- [3] Y. Cui, Self-Sensing Compounding Control of Piezoceramic Micro-Motion Worktable Based on Integrator, *Proc. to 6th World Congress on Intell. Cont. and Autom.*, China, 2006.
- [4] A. S. Putra, H. Sunan, T. K. Kok, S.K. Panda and T. H. Lee, Self-Sensing Actuation With Adaptive Control in Applications With Switching Trajectory, *IEEE/ASME Trans. on Mechatronics*, vol. 13, no. 1, pp. 104-110, 2008.
- [5] M. Rakotondrabe, I. A. Ivan, S. Khadraoui, C. Clévy, P. Lutz and N. Chaillet, 'Dynamic displacement self-sensing and robust control of cantilevered piezoelectric actuators dedicated to microassembly tasks', *IEEE/ASME - AIM*, pp:557-562, July 2010.

- [6] Gourishankar, V., Kudva, P., and Ramar, K., 1977, *Int. J. Control.* vol. 25, pp. 311.
- [7] Muller, P.C., 1990, 'Indirect measurements of nonlinear effects by state observers', *IUTAM Sysmp.. Nonlinear Dynamics in Engineering Systems*, University of Stuttgart, Springer, Berlin, pp. 205-215.
- [8] Martin Corless and Jay Tu, "State and input estimation for a class of uncertain systems", *Automatica*, pp.757-764, Volume 34(6), June 1998.
- [9] Chen, M.-S. and Tomizuka, M., 'Disturbance estimator and its application in estimation of system output derivative', *CDC*, pp. 452-457, 1989.
- [10] Chen, M.-S., 'Uncertainty estimator', *American Control Conference*, pp. 2020-2024, 1990.
- [11] Tu, J.F. and Stein, J.L., 'Modeling error compensation for bearing temperature and preload estimation', *Journal of Dynamic Systems, Measurements, and Control*, vol. 118, pp. 580-585, n 1996.
- [12] Darouach, M., Zasadzinski, M., and Xu, S.J., 'Full-order observers for linear systems with unknown inputs', *IEEE Transactions on Automat. Contr.*, vol. 39, pp. 606-609 1994.
- [13] Tu, J.F. and Stein, J.L., 'On-line preload monitoring for high-speed anti-friction spindle bearings', *Journal of Dynamic Systems, Measurements, and Control*, vol. 117, pp. 43-53, 1995.
- [14] C-S. Liu and H. Peng, 'Inverse-dynamics based state and disturbance observers for linear time-invariant systems', *ASME J. of Dynamics Systems, Measurement and Control*, vol.124, pp.375-381, Sep. 2002.
- [15] M. Rakotondrabe, C. Clévy and P. Lutz, "Complete open loop control of hysteretic, creep and oscillating piezoelectric cantilevers", *IEEE Transactions on Automation Science and Engineering*, DOI 10.1109/TASE.2009.2028617.
- [16] K. Kuhnen and H. Janocha, "Inverse feedforward controller for complex hysteretic nonlinearities in smart-materials systems", *Control of Intelligent System*, Vol.29, N°3, 2001.
- [17] W. T. Ang, P. K. Kholsa and C. N. Riviere, "Feedforward controller with inverse rate-dependent model for piezoelectric actuators in trajectory-tracking applications", *IEEE/ASME Transactions on Mechatronics (Tmech)*, Vol.12(2), pp.134-142, April 2007.
- [18] B. Mokaberi and A. A. G. Requicha, "Compensation of scanner creep and hysteresis for AFM nanomanipulation", *IEEE Transactions on Automation Science and Engineering*, Vol.5, N°2, pp.197-208, 2008.
- [19] Micky Rakotondrabe, 'Classical Prandtl-Ishlinskii modeling and inverse multiplicative structure to compensate hysteresis in piezoactuators', *ACC*, (American Control Conference), pp.1646-1651, Montréal Canada, June 2012.
- [20] Joël Agnus, Nicolas Chaillet, Cédric Clévy, Soukalo Dembélé, Michaël Gauthier, Yassine Haddab, Guillaume Laurent, Philippe Lutz, Nadine Piat and Micky Rakotondrabe, 'Robotic Microassembly and micromanipulation at FEMTO-ST', *Journal of Micro-Nano Mechatronics*, in press 2012.
- [21] Micky Rakotondrabe and P. Lutz, 'Force estimation in a piezoelectric cantilever using the inverse-dynamics-based UIO technique', *IEEE Int. Conf. on Robot.and Autom. (ICRA)*, pp.2205-2210, Kobe JP, May 2009.
- [22] Micky Rakotondrabe, Y. Haddab and P. Lutz, "Quadrilateral modeling and robust control of a nonlinear piezoelectric cantilever", *IEEE Trans. on Control Systems Technology (TCST)*, Vol.17(3), pp.528-539, May 2009.